

**PERFORMANCE SPECIFICATION  
FOR SINGLE-SIDEBAND  
RADIOTELEPHONE TRANSMITTING  
AND RECEIVING EQUIPMENT  
OPERATING IN THE FREQUENCY BAND  
1.605 MHz TO 27.5 MHz FOR VOLUNTARY  
FITTING IN SMALL CRAFT**



## FOREWORD

1. This specification is prescribed under section 32D of the Telecommunications Ordinance (Cap 106) (“the Ordinance”) to set out the technical and evaluation requirements for single-sideband radiotelephone transmitting and receiving equipment operating in the frequency band 1.605 MHz - 27.5 MHz for voluntary fitting in small craft. Radiocommunications apparatus falling into the scope of this specification shall meet the stipulated requirements.
2. Under the Ordinance, the possession or use of any radiocommunications apparatus or any apparatus emitting radio frequency energy must be covered by an appropriate licence issued by the Telecommunications Authority (CTA) with the exception of those specifically exempted from licensing under the Ordinance, such as those covered by the Telecommunications (Telecommunications Apparatus)(Exemption from Licensing) Order.
3. At present, the Office of the Telecommunications Authority (OFCFTA) operates a Hong Kong Telecommunications Equipment Evaluation and Certification (HKTEC) Scheme. Details of the HKTEC Scheme can be found in the information note OFCFTA I 421. Under the Scheme, suppliers or manufacturers of the radiocommunications apparatus shall apply for certification of their apparatus against this specification. The application procedures for certification of radiocommunications apparatus can be found in the information note OFCFTA I 401.
4. The TCA may amend any part of this specification as and when ~~he~~ it deems necessary.
5. In case of doubt about the interpretation of this specification, the methods of carrying out the test and the validity of statements made by the equipment manufacturers or suppliers about the equipment, the decision of the CTA shall be final.
6. The HKCTA specifications and information notes issued by the CTA can be downloaded from OFCFTA’s website at <http://www.ofcta.gov.hk>. Enquiries about this specification may be directed to:

Senior Telecommunications Engineer,  
Standards Section,  
Office of the Telecommunications Authority,  
29/F Wu Chung House,  
213 Queen’s Road East,  
Wanchai,  
Hong Kong.

Fax: +852 2838 5004

Email: [standards@ofcta.gov.hk](mailto:standards@ofcta.gov.hk)

## AMENDMENT TABLE

Item	Issue No.	Paragraph	Descriptions
1.	Issue 03 February 2003	Foreword	Add information of HKTEC Scheme and other editorial changes.
2.	Issue 04 June 2005	5	Update channel frequencies and other editorial changes.
3.	Issue 05 October 2010	2.3.1	Remove atmospheric pressure requirement.
4.	Issue 05 October 2010	3.2.2	Update the reference to international standard.
<u>5.</u>	<u>Issue 06</u> <u>MM 2022</u>	<u>Foreword</u>	<u>Replace TA and HKTA by CA and HKCA respectively and other editorial changes</u>
<u>6.</u>	<u>Issue 06</u> <u>MM 2022</u>	<u>1.4</u>	<u>Remove electrical safety requirements and re-number the subsequent paragraphs accordingly</u>

## CONTENTS

- 1 GENERAL
  - 1.1 Scope of specification
  - 1.2 Construction and design
  - 1.3 Controls and indications
  - ~~1.4 Safety precautions~~
  - 1.45 Classes of emission and frequency bands
  - 1.56 Frequency and channel arrangements
  - 1.67 Artificial antenna
  
- 2 TEST CONDITIONS, POWER SUPPLIES, AND AMBIENT TEMPERATURES
  - 2.1 Normal and extreme test conditions
  - 2.2 Test power source
  - 2.3 Normal test conditions
  - 2.4 Extreme test conditions
  - 2.5 Procedure for tests at extreme temperatures
  - 2.6 Warming-up period
  - 2.7 Standard output power
  
- 3 TRANSMITTER
  - 3.1 Frequency accuracy
  - 3.2 Output power
  - 3.3 Automatic level control and/or limiter
  - 3.4 Power of unwanted emissions
  - 3.5 Hum and noise power
  - 3.6 Continuous operation
  - 3.7 Protection of transmitter
  
- 4 RECEIVER
  - 4.1 Tuning error and tuning drift
  - 4.2 Maximum usable sensitivity
  - 4.3 Adjacent-signal selectivity
  - 4.4 Blocking and cross-modulation
  - 4.5 Intermodulation
  - 4.6 Spurious responses
  - 4.7 Spurious emissions
  - 4.8 Internally generated spurious signals
  - 4.9 Protection of input circuits
  - 4.10 Speech clarifier
  
- 5 TABLE FOR FREQUENCY AND CHANNEL ARRANGEMENTS
  
- 6 FIGURE

# **1 GENERAL**

## **1.1 Scope of specification**

This specification states the minimum performance requirements for single sideband radiotelephone transmitters and receivers, installed with whip antenna, for voluntary fitting on small craft (e.g. fishing vessels, pleasure vessels) licensed by the Marine Department, Hong Kong, operating in the medium frequency and high frequency bands allocated in the Radio Regulations to the Maritime Mobile Service.

## **1.2 Construction and design**

1.2.1 In all respects the mechanical and electrical design shall conform to good engineering practice, and the equipment shall be suitable for use on board small craft at sea.

1.2.2 A label showing the type number under which the equipment is submitted for type testing, shall be fitted to the equipment so as to be clearly visible in the normal operation position.

1.2.3 Duplex operation shall be safeguarded and precautions shall be taken to prevent harmful electric or acoustic feedback which could cause singing.

## **1.3 Controls and indications**

1.3.1 All adjustments and controls necessary for switching the transmitter to operate on 2182 kHz shall be clearly marked in order that this operation can be easily performed.

1.3.2 All controls shall be of such size as to permit normal adjustments to be performed and the number of the controls should be the minimum necessary for satisfactory and simple operation.

1.3.3 All controls, instruments, indicators, and terminals shall be clearly labelled.

1.3.4 Switching shall be provided to change the equipment from the receiving condition to the transmitting condition and vice versa without it being necessary to operate any other control. If manual switching is used, a switch for this purpose shall be located on the microphone or telephone handset. This switch shall, when at rest, leave the equipment in the receive condition.

1.3.5 Indication shall be provided to denote there is a transmission in the transmission mode.

1.3.6 It shall be possible to change the transmitter from operation on any frequency to operation on any other frequency in the same maritime mobile band within a period not exceeding 15 seconds. For transmitters designed to operate in more

than one maritime mobile band the time allowed for changing the transmitter from operation on any specified frequency in one maritime mobile band to operation on any specified frequency in any other maritime mobile band for which it is designed shall not exceed 30 seconds.

However, the time allowed to change the transmitter from operation on any frequency in any band for which it is designed, to operation on 2182 kHz, shall not exceed 15 seconds. The same time limits shall apply to changing the frequency of the receiver.

#### ~~1.4~~ **Safety precautions**

~~1.4.1~~ Provision shall be made for protecting the equipment from the effects of excessive current or voltage, voltage polarity reversal, and from excessive rise of temperature in any part of the equipment.

~~1.4.2~~ Provision shall be provided to avoid electrical shock when the protective covers of the equipment are removed.

#### **1.45** Classes of emission and frequency bands

~~1.45.1~~ Classes of emission

~~1.45.1.1~~ The equipment shall provide for the transmission and/or reception of upper sideband signals of the classes of emission stated below :

1. J3E single sideband with the carrier suppressed at least 40 dB below peak envelope power.
2. H3E single sideband with the carrier 4.5 - 6 dB below peak envelope power shall be provided on 2182 kHz.

~~1.45.1.2~~ It shall be possible to change the emission of the transmitter from any class to any other class, for which it is designed to operate, by not more than one control.

~~1.45.1.3~~ When switched to the distress frequency 2182 kHz, the class of emission H3E shall be selected automatically.

~~1.45.1.4~~ In order to permit the use of class of emission J3E on the distress frequency 2182 kHz, provision may be made for overriding the automatic selection of class of emission H3E after the equipment has been switched to the frequency 2182 kHz.

~~1.45.2~~ Frequency bands

~~1.45.2.1~~ Medium frequency bands

The equipment shall provide for the transmission and/or reception in the appropriate frequency bands between 1605 kHz and 4000 kHz allocated in the Radio Regulations to the Maritime Mobile Service.

#### 1.45.2.2 High frequency bands

The equipment shall provide for the transmission and/or reception in the appropriate frequency bands between 4 MHz and 27.5 MHz allocated in the Radio Regulations to the Maritime Mobile Service.

### 1.56 Frequency and channel arrangements

1.56.1 A minimum capability of two single-frequency simplex or two two-frequency simplex channels shall be provided in each of the 2, 4, 6 and 8 MHz frequency bands allocated for maritime radiotelephone, i.e. 8 channels. Separate selection of transmit and receive frequencies is not permitted. These channels shall include 2182 kHz, the Medium Frequency radiotelephone distress and calling channel and the 4 and 6 MHz High Frequency supplementary distress and calling channels. The remaining channels shall be specified by the Authority and will normally include one or two 2 MHz and one 4 MHz intership channel together with at least one ship-shore working channel in each of the 4, 6 and 8 MHz frequency bands. Free (continuous) selection of frequency is not permitted, and any synthesizer must be programmed for authorized frequencies only. For information, the radio channel could be arranged in a manner as shown in Clause 5.

### 1.67 Artificial antenna

1.67.1 For the purpose of type testing, the transmitter and the receiver shall meet the requirements of this specification when connected to the appropriate artificial antenna given below. This shall in no way imply that the transmitter and the receiver shall only work with antennae having these characteristics :

1. 1605 - 4000 kHz

The artificial antenna shall consist of a resistance of 10 ohms and a capacitance of 250 pF connected in series.

2. 4 - 27.5 MHz

The artificial antenna shall consist of a non-reactive resistance of 50 ohms.

1.67.2 Sources of test signals for application to the receiver input shall be connected through a network such that the impedance presented to the receiver input is equal to that of the artificial antenna specified in Clause 1.7.1. This requirement shall be met irrespective of whether one, two or more test signals are applied to the receiver simultaneously.

## **2 TEST CONDITIONS, POWER SUPPLIES, AND AMBIENT TEMPERATURES**

### **2.1 Normal and extreme test conditions**

Type approval tests shall be made under normal test conditions, and also, where stated, under extreme test conditions. The test conditions and procedures shall be as specified in Clauses 2.2 to 2.5.

### **2.2 Test power source**

During type approval tests the equipment shall be supplied from a test power source, capable of producing normal and extreme test voltages as specified in Clauses 2.3.2 and 2.4.2.

The test power source voltage shall be maintained with a tolerance  $\pm 3\%$  relative to the voltage at the beginning of each test.

### **2.3 Normal test conditions**

#### **2.3.1 Normal atmospheric condition**

The normal atmospheric conditions for tests shall be any convenient combination of temperature and relative humidity within the following ranges :

1. Temperature : 15°C to 35°C
2. Relative humidity : 10 % to 80 %

NOTE : When it is impracticable to carry out the test under the conditions stated above, a note to this effect, stating the actual temperature and relative humidity during the tests, shall be added to the test report.

#### **2.3.2 Normal test power source**

##### **2.3.2.1 Mains voltage and mains frequency**

The normal test voltage for equipment to be connected to the mains shall be the nominal mains voltage. For the purpose of this specification, the nominal voltage shall be the declared voltage or any of the declared voltages for which the equipment was designed. The frequency of the test power source corresponding to the AC mains shall be 50 Hz  $\pm$  1 Hz.

##### **2.3.2.2 Secondary battery power sources**

When the equipment is intended for operation from a secondary battery power



source the normal test voltage shall be the nominal voltage of the battery (e.g. 12 volts, 24 volts, etc.).

## **2.4 Extreme test conditions**

### **2.4.1 Extreme temperatures**

For test at extreme temperatures, measurements shall be made in accordance with the procedures specified in Clause 2.5, at the lower and upper temperatures of 0°C and 40°C respectively.

### **2.4.2 Mains voltage and mains frequency**

The extreme test voltage for equipment to be connected to an AC mains source shall be the nominal mains voltage  $\pm 10\%$ . The frequency of the test power source shall be 50 Hz  $\pm 1$  Hz.

### **2.4.3 Secondary battery power sources**

When the equipment is intended for operation from a secondary battery power source the extreme test voltage shall be 1.3 and 0.9 times the nominal voltage of the battery (e.g. 1.3 and 0.9 times 12 volts, 24 volts, etc.).

## **2.5 Procedure for tests at extreme temperatures**

After tests at any convenient temperature as specified in Clause 2.3.1 the equipment shall be switched off and placed in a temperature controlled chamber capable of maintaining a constant temperature with a tolerance of  $\pm 3^\circ\text{C}$  and without condensation. Before making measurements the equipment shall have reached thermal balance in the test chamber. If the thermal balance is not recorded by measurements, a temperature stabilizing period of at least one hour, or such period as may be decided by the testing authority, shall be allowed.

## **2.6 Warming-up period**

2.6.1 The equipment shall be operational within 30 seconds after switching on.

2.6.2 The equipment shall be operational and shall meet the requirements of this specification one minute after switching on, except as provided in Clause 2.6.3.

2.6.3 If the equipment includes parts which require to be heated in order to operate correctly, for example, crystal ovens, then a warming-up period of 30 minutes from the instant of application of power to those parts shall be allowed, after which the requirements of this specifications shall be met.

2.6.4 Where Clause 2.6.3 is applicable the power supplies to the heating circuits shall be arranged so that they can remain operative when other supplies to the equipment or within the equipment are switched off. If a special switch for these circuits is

provided on the equipment, the function of the switch shall be clearly indicated and the operating instructions shall state that the circuit should normally be left connected to the supply voltage.

## **2.7 Receiver standard output power**

The receiver standard output power is 1 mW for headphone reception and 50 mW for loudspeaker reception when measured at a frequency of 1 kHz.

## **3 TRANSMITTER**

### **3.1 Frequency Accuracy**

#### **3.1.1 Definition**

The frequency accuracy of the transmitter is the difference between the unmodulated carrier frequency and the nominal frequency.

#### **3.1.2 Method of measurement**

The transmitter under test shall be connected as shown in Figure 1 and operated in accordance with the manufacturer's instruction to obtain the output power determined in Clause 3.2.2.

The transmitter carrier frequency shall be measured under normal test conditions and repeated under extreme test conditions.

#### **3.1.3 Limits**

The transmitter carrier frequencies shall, at all times after warning-up period specified in Clause 2.6 be maintained within  $\pm 40$  Hz for frequencies in the band 1605 kHz to 4 MHz, and within  $\pm 50$  Hz for frequencies in the band 4 MHz to 27.5 MHz, under normal and extreme test conditions.

Any unwanted frequency modulation of the carrier shall be sufficiently low to prevent harmful distortion being produced.

## **3.2 Output power**

### 3.2.1 Definition

The output power of the transmitter is measured in terms of the peak envelope power (p-e-p). The rated peak envelope power shall be that declared by the manufacturer at which all the specified requirements are met.

### 3.2.2 Method of measurement

The output power in the artificial antenna shall be measured by the two modulating oscillations method given for SSB transmitters in the prevailing version of ITU-R Rec. SM.326.

The measurement shall be made under normal test conditions and repeated under extreme test conditions.

### 3.2.3 Limits

The minimum rated power output shall be 100 watts peak envelope power (p-e-p) when measured into a non-inductive resistor of value 50 ohms. The maximum rated power shall be limited to 150 watts p-e-p. At the rated output power, the intermodulation level shall not exceed -25 dB.

## **3.3 Automatic level control and/or limiter**

### 3.3.1 Definition

The automatic level control and/or limiter performance is a measure of the variation in the output power of the transmitter for a given variation in the level of the input modulating signal.

### 3.3.2 Method of measurement

The transmitter shall be modulated by a test signal consisting of two audio frequency tones of equal amplitude, on frequencies between 350 Hz and 2700 Hz, applied to the modulation input. The individual modulation tones shall not be harmonically related and shall be separated in frequency by at least 100 Hz. The level of the test signal shall be varied and the level of the input signal together with the corresponding values of peak envelope power shall be measured at a sufficient number of points for a graph of input level against peak envelope power to be plotted.

### 3.3.3 Limits

When the modulating input level is increased by 10 dB from that required to produce the rated output power of the transmitter, the steady state increase in the output power shall not exceed 1 dB and the intermodulation level shall not exceed -25 dB. The input signal level corresponding to a transmitter output power of -10

dB relative to rated output power shall be recorded.

### 3.4 Power of unwanted emissions

#### 3.4.1 Definition

Unwanted emissions are emissions at frequencies other than those of the carrier and sidebands associated with normal modulation resulting from signals generated within the equipment.

#### 3.4.2 Method of Measurement

The transmitter shall be driven to the rated power by a modulating signal consisting of two audio-frequency tones with a frequency separation between them such that all intermodulation products occur at frequencies at least 1500 Hz removed from the assigned frequency. Under these conditions, the power of any unwanted emission, at any discrete frequency, supplied to the artificial antenna shall be measured. Any limiter or automatic control of the modulation level shall be in normal operation.

#### 3.4.3 Limits

The measured power of the unwanted emissions shall not exceed the limits given in the Table 1 below :

Separation ( $\Delta$ ) in kHz between the frequency of the unwanted emission and the assigned frequency	Minimum attenuation below peak envelope power
(i) $1.5 < \Delta \leq 4.5$	(i) 31 dB
(ii) $4.5 < \Delta \leq 7.5$	(ii) 38 dB
(iii) $7.5 < \Delta$	(iii) 43 dB without exceeding the power of 50 mW

Table 1 : Limits of unwanted emission

The emission of unwanted components, including noise, shall not reach a level such that, when working duplex, the operation of an associated receiver is seriously affected.

### 3.5 Hum and noise power

With the input audio frequency terminals open-circuited and also when they are short-circuited, the total hum and noise power within the bandwidth of the transmitter, measured in the artificial antenna, shall be at least 40 dB below the rated peak envelope power.

### 3.6 Continuous operation

When the transmitter is driven at its rated power by two sinusoidal audio-frequency components at the input, it shall be capable of operating continuously for a period of 15 minutes without appreciable reduction of power and without harmful effects.

### **3.7 Protection of transmitter**

When the transmitter is driven to the rated output power by the simultaneous application of two modulating signals of equal level, and the antenna terminals are short-circuited or open-circuited, in each case for a period of 5 minutes, no damage shall occur.

## **4 RECEIVER**

### **4.1 Tuning error and tuning drift**

#### **4.1.1 Definition**

Tuning error is the amount by which the frequency indicated on the receiver differs from the carrier frequency of an input signal to which the receiver is tuned.

Tuning drift is the amount by which the tuning changes over a period of time in absence of adjustments to the receiver.

#### **4.1.2 Method of measurement of tuning error**

Measurements shall be carried out at a number of frequencies sufficient to establish the tuning error over all the ranges of frequency for which the receiver is designed. The measurements shall be carried out under normal test conditions, and where practicable under extreme test conditions. An unmodulated radio frequency test signal, representing the nominal carrier frequency plus 1000 Hz shall be applied to the input of the receiver, the frequency accuracy of the test signal being  $\pm 3$  Hz. With the speech clarifier set to the middle of its range the channel selector shall be switched to the position corresponding to the frequency of the test signal. The output frequency shall then be measured and the difference between 1000 Hz and the measured output frequency determined.

#### **4.1.3 Limits for tuning error**

The tuning error shall not exceed  $\pm 50$  Hz.

#### **4.1.4 Method of measurement of tuning drift**

An unmodulated radio frequency test signal, representing the nominal carrier frequency plus 1000 Hz shall be applied to the input of the receiver, the frequency accuracy of the test signal being  $\pm 3$  Hz. The speech clarifier of the receiver shall be set to a position near the middle of its range. The input frequency shall be

kept constant and the output frequency shall then be measured at suitable intervals of time, the results being used to determine the tuning drift. During these measurements the ambient temperature shall be held constant at  $\pm 3^{\circ}\text{C}$ . Tests shall be made at normal and extreme test conditions.

#### 4.1.5 Limits for tuning drift

In any period of 15 minutes after the warming up period specified in Clause 2.6 the difference between the output frequency at any moment and the output frequency at the commencement of the 15 minutes period shall not exceed 20 Hz.

The measured frequencies shall at all times be within the range 950 to 1050 Hz.

## 4.2 Maximum usable sensitivity

### 4.2.1 Definition

This maximum usable sensitivity is the minimum level of a radio frequency input signal with specified modulation which will produce at the receiver output a chosen value of signal plus noise plus distortion to noise ratio (abbreviated SND/N) or of a signal plus noise plus distortion to noise plus distortion ratio (abbreviated SND/ND) and, at the same time, an audio output power not less than the receiver standard output power.

### 4.2.2 Method of measurement

With the automatic gain control operative, tests shall be carried out with the receiver adjusted for each frequency range and class of emission for which it is designed.

For reception of classes of emission J3E, an unmodulated input signal 1000 Hz above the carrier frequency to which the receiver is tuned, shall be used. For reception of classes of emission H3E, an input signal at the carrier frequency, modulated to a depth of 30% at 1000 Hz, shall be used. For each test the input level of the test signal shall be adjusted until the SND/N or SND/ND ratio at the receiver output is 20 dB, and at the same time at least the standard output power is obtained. The measured input level is the maximum usable sensitivity.

### 4.2.3 Limits

#### 4.2.3.1 For the MF range the maximum usable sensitivity shall be better than :

- a. +16 dB $\mu$ V for class of emission J3E
- b. +30 dB $\mu$ V for class of emission H3E

#### 4.2.3.2 For the HF range with class of emission J3E, the maximum usable sensitivity shall be better than +11 dB $\mu$ V.

## 4.3 Adjacent-signal selectivity

#### 4.3.1 Definition

The adjacent-signal selectivity is defined as the ratio of the levels at the receiver input, of specified unwanted signals to specified wanted signals, which result in a reduction of the SND/N or SND/ND ratio from 20 dB to 14 dB.

#### 4.3.2 Method of measurement

The arrangements for applying two test signals to the receiver input, shall be according to Clause 1.7.2. The automatic gain control shall be in operation. The wanted test signal shall be :

1. for class of emission J3E, and unmodulated signal, 1000 Hz above the carrier frequency to which the receiver is tuned.
2. for class of emission H3E, a signal at the carrier frequency to which the receiver is tuned, modulated to a depth of 30% at 1000 Hz.

The receiver shall be adjusted to give the receiver standard output power on the wanted frequency, and to give a SND/N or SND/ND ratio of 20 dB.

An unwanted signal shall then be applied to the receiver input. This signal shall be modulated to a depth of 30% at 400 Hz. The level of the unwanted signal shall be increased (starting from a low level), until the SND/N or SND/ND ratio, is decreased from 20 dB to 14 dB.

#### 4.3.3 Limits

The adjacent-signal selectivity shall exceed the values given in Table 2 and Table 3.

Frequency of unwanted signal relative to carrier frequency of wanted signal	Adjacent-signal selectivity
-1 kHz and +4 kHz	40 dB
-2 kHz and +5 kHz	50 dB
-5 kHz and +8 kHz	60 dB

Table 2 : Values for class of emission J3E

Frequency of unwanted signal relative to carrier frequency of wanted signal	Adjacent-signal selectivity
-10 kHz and +10 kHz	40 dB
-20 kHz and +20 kHz	50 dB

Table 3 : Values for class of emission H3E

### 4.4 Blocking and cross-modulation

#### 4.4.1 Definition

Blocking is a change (generally a reduction) in the wanted output power of a receiver, or a reduction in the SND/N ratio, due to an unwanted signal on another frequency.

Cross-modulation is the transfer of modulation from an unwanted, modulated signal on another frequency to the wanted signal. Blocking and cross-modulation often occur at the same time.

#### 4.4.2 Method of measurement

4.4.2.1 The tests shall be carried out with the automatic gain control operative. The measurements shall be made by means of the simultaneous application of two test signals to the input of the receiver. One of the test signals is the wanted signal to which the receiver is tuned, and the other is the unwanted signal.

4.4.2.2 Measurements on blocking and cross-modulation shall be carried out with an input level of the wanted signal of +60 dB $\mu$ V. The blocking measurement shall be repeated with the wanted signal at a level equal to the maximum usable sensitivity of the receiver.

4.4.2.3 For tests of the reception of class of emission J3E, the wanted test signal shall be an unmodulated signal 1000 Hz above the carrier frequency to which the receiver is tuned.

For tests of the reception of class of emission H3E, the wanted test signal shall be a signal at the carrier frequency to which the receiver is tuned, modulated to a depth of 30% at 1000 Hz.

4.4.2.4 For the blocking test, the receiver shall be adjusted so that the wanted signal gives standard output power. An unwanted unmodulated signal, having a frequency of  $\pm 20$  kHz relative to that of the wanted signal shall then be applied. The input level of the unwanted signal shall be adjusted until either it causes a change of 3 dB in the output level of the wanted signal, or until it causes a reduction of the SND/N ratio of 6 dB, whichever effect occurs first. The input level of the unwanted signal, when the specified condition is reached, shall be taken as the blocking level. When performing the above measurements precautions have to be taken that the distortion components in the output signal do not influence the results appreciably.

4.4.2.5 For the cross-modulation test, the receiver shall be adjusted so that the wanted signal gives standard output power. The unwanted signal, having a frequency of  $\pm 20$  kHz relative to that of the wanted signal and modulated to a depth of 30% at 400 Hz, shall then be applied. The input level of the unwanted signal shall be increased until total unwanted power in the receiver output due to cross-modulation is 30 dB below the level of the wanted signal. The input of the unwanted signal, at which this condition is obtained, shall be taken as the cross-modulation level.



#### 4.4.3 Limits

##### 1. Blocking

- a. With the wanted signal 60 dB $\mu$ V, the level of the unwanted signal shall not be less than 100 dB $\mu$ V.
- b. With the wanted signal at a level equal to the maximum usable sensitivity, the level of the unwanted signal shall be at least +65 dB above this sensitivity level.

2. For cross-modulation, the level of the unwanted signal shall not be less than 90 dB $\mu$ V.

#### 4.5 Intermodulation

##### 4.5.1 Definition

Intermodulation is a process by which signals are produced from two or more (generally unwanted) signals simultaneously present in a non-linear circuit.

##### 4.5.2 Method of measurement

###### 4.5.2.1 Class of emission J3E

With the automatic gain control operative and the RF/IF gain control at its maximum, an unmodulated input signal 2000 Hz higher than the frequency to which the receiver is tuned shall be applied to the receiver input at a level of 30 dB $\mu$ V and the audio frequency gain control shall be adjusted to give the receiver standard output power. The wanted signal shall then be removed and two equal level unmodulated signals shall be simultaneously applied to the input of the receiver. Neither of the two signals shall have a frequency within 30 kHz from the wanted signal (input frequencies likely to cause unwanted intermodulation products are mentioned in CCIR Recommendation 332-4, Section 6.4). When choosing the frequencies used for this measurement care should be taken to avoid frequencies at which spurious responses occur. The input levels of the two interfering signals shall remain equal and shall be adjusted until the output power of the receiver due to the interfering signals is equal to the standard output power. If the output/input characteristic is not suitable for determining these input levels precisely, it should be ensured that the automatic gain control conditions are the same as with the wanted signal for example by using the automatic gain control voltage as the reference.

#### 4.5.2.2 Class of emission H3E

The method of measurement is the same as for class of emission J3E with two exceptions :

1. the wanted test signal shall be a signal of the carrier frequency modulated to a depth of 30% at 1000 Hz.
2. the unwanted signal which has the greatest frequency separation from the wanted signal, shall be modulated to a depth of 30% at 1000 Hz. The other unwanted signal shall be unmodulated.

#### 4.5.3 Limits

The level of each of the two interfering signals which resulted in standard output shall not be less than +80 dB $\mu$ V.

### 4.6 Spurious responses

#### 4.6.1 Definition

The spurious response rejection ratio is the ratio of the input level of an unwanted signal, at the frequency of the spurious response to the input level of a wanted signal, when the wanted and unwanted signals individually produce the same SND/N or SND/ND ratio at the receiver output.

#### 4.6.2 Method of measurement

The receiver shall be adjusted in accordance with Clause 4.2 (sensitivity test). All receiver controls shall remain unaltered during the remainder of the test. The carrier frequency of the input signal shall then be varied to search for spurious responses. For each spurious response found the carrier frequency of the input signal shall be adjusted to give maximum output power. The input level shall then be adjusted to give a SND/N or SND/ND ratio of 20 dB at the output of the receiver. The ratio between the input level of each spurious signal and the input level of the wanted signal shall then be evaluated.

#### 4.6.3 Limits

##### 4.6.3.1 The image frequency rejection ratio shall not be less than the values given below :

1. 60 dB when wanted signal is in the frequency range 1605 kHz - 15 MHz.
2. 50 dB when wanted signal is in the frequency range 15 - 28 MHz.

##### 4.6.3.2 The intermediate frequency rejection ratio shall be at least 60 dB.

##### 4.6.3.3 The rejection ratio of other spurious responses shall be at least 60 dB.

### 4.7 Spurious emissions

#### 4.7.1 Definition

Spurious emissions are any radio frequency emissions generated in the receiver and radiated either by way of conduction to the antenna or other conductors connected to the receiver, or radiated directly by the receiver.

#### 4.7.2 Methods of measurement

Spurious emissions radiated by the antenna shall be tested by means of measurements on the artificial antennas specified in Clause 1.7. The artificial antenna shall be connected to the receiver. A search shall be made for the presence of signals in the artificial antenna, using a spectrum analyser or other instrument. The r.m.s. voltage of any component of the spurious emission shall be evaluated.

#### 4.7.3 Specified limits

The power of any discrete component measured in the artificial antenna shall not exceed 20 nW.

### 4.8 Internally generated spurious signals

Internally generated spurious signals shall not produce an audio output level greater than 10 dB above the normal inherent noise level of the receiver in the bands allocated to the maritime mobile service.

### 4.9 Protection of input circuits

The receiver shall not suffer damage when an unmodulated radio frequency test signal, representing the nominal carrier frequency at a level of 30 volts r.m.s, is applied, in the manner specified in Clause 4.1.2 to its input for a period of 15 minutes. The receiver shall operate normally without further attention when the test signal is removed. The receiver shall also have means of protection against damage due to static voltages which may appear at its input.

### 4.10 Speech clarifier

The speech clarifier of the receiver shall be capable of reducing the frequency error to 10 Hz or less. The movement and the range of the clarifier control shall be sufficient to permit the adjustment to be easily performed. The frequency range of the speech clarifier shall be at least  $\pm 80$  Hz and preferably not more than  $\pm 200$  Hz.

5

**TABLE FOR FREQUENCY AND CHANNEL ARRANGEMENTS**

Channel Position	Ship Transmits (kHz)	Ship Receives (kHz)	Purpose
1	2182	2182	international distress, safety & calling
2	2231	2231	intership (HK fishing vessels)
3	4149	4149	intership (HK fishing vessels)
4	4125	4417	supplementary distress & calling
5	4095	4387	ship-shore working
6	6215	6516	supplementary distress & calling
7	6218	6519	ship-shore working
8	8288	8812	ship-shore working
9	12320	13167	calling & ship-shore working
10	12347	13194	ship-shore working
11	2042.5	2060	ship-shore working (HK fishing vessels)
12	2431	2431	intership (HK ship)

6 **FIGURE**

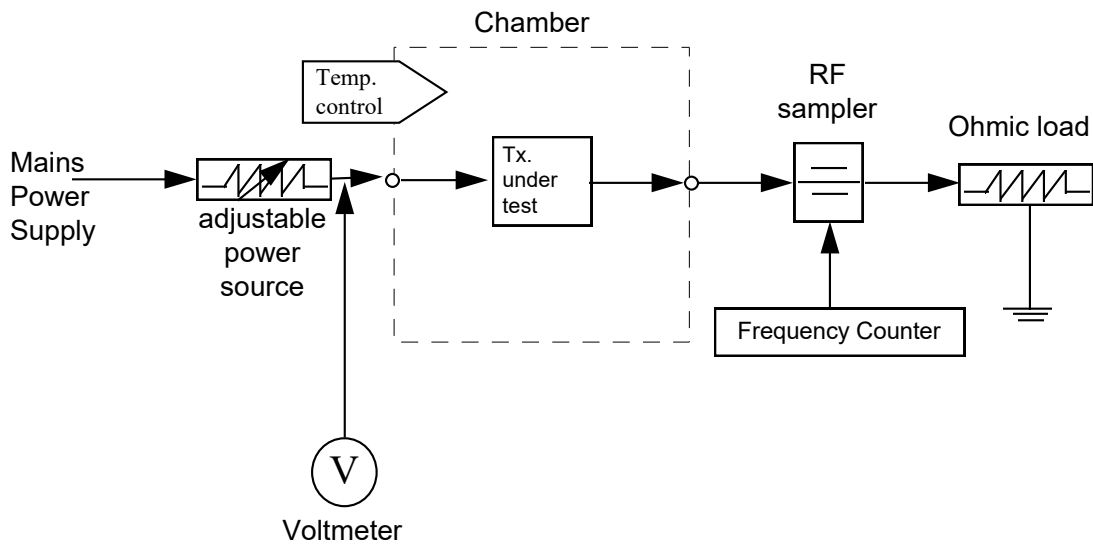

Figure 1 : Frequency Error Test Arrangement

- END -